



DIGITUS 19" ECOLINE racks provide an economical solution for free standing cabinets. Sturdy and compact, the ECOLINE features a modular design ideal for network applications of offices, private and government buildings, schools, hotels and all indoor applications.

ECOLINE modular cabinets come prepackaged in standard light gray (ral7035), metal with glass door.

19" Digitus Ecoline Cabinets and Racks



FEATURES

- *Secure, locking front and back doors with spring loaded hinges.
- *Front door features a full-length smoked shatterproof glass panel with decorative accent trim, and integrated locking mechanism
- *Multiple cable entry points provide maximum versatility. There is a sliding access panel on the bottom. There are prepunched holes on the top of the cabinet, rear side of bottom and top cases.
- *Solid metal bottom with access panel
- *Non-opening side panels are used as upright frames (unique body) gives extra stability.
- *Adjustable front and back mounting rails allow for flexible configuration
- *Available in both 600mm. and 800mm. depths.
- *Three sets of front-to-back metal rods for stability.
- *Available in light gray with orange accent, or blue, or green.
- *Versatile-can be used in varied locations and environments, yet stylishly designed for showcase applications.
- *Dedicated space for top mount cooling system (system not included)

Load Carrying Capacity: 400 kg

STANDARDS

- *ISO 9001:2000
- *19" mounting to IEC 297-1
- *Overall cabinet dimensions to IEC 297-2

COMPLIANCES

UL and cUL

IP Protection: IP20

Glass : 4mm Secure and tempered

Surface Treatment : Fosfat coating

Painting : Ral7035 / Ral9005

Locks : Emka Germany

Handle type : KLT- E1150433-03 / Password Code : 9473

O-type : KLT - E7308 / Password Code : 9473

Small O-type : KLT – E7158 / Password Code : 827

Well Packaged : Shrinked plastic with inner surface and outside is covered by wooden box.

Material Definition and Properties, Thicknesses and Shipment Configuration

Part Definition	Material thickness	Material definition & properties	Shipment Configuration
Caster Profile	2 mm	GALVANIZED	4 ea.
Upper Case	1,5 mm	DIN EN 10130 – 99 EREGLI DC-01 6112 CRS	1 ea.
Bottom Case	1,5 mm	DIN EN 10130 – 99 EREGLI DC-01 6112 CRS	1 ea.
Side Doors	1,5 mm	DIN EN 10130 – 99 EREGLI DC-01 7122 CRS	2 ea.
19" mounting angles	1,5 mm	DIN EN 10130 – 99 EREGLI DC-01 6112 & GALVANIZED COATING	4 ea. (2ea. at front , 2ea. at rear)
C-rails	1,5 mm	DIN EN 10130 – 99 EREGLI DC-01 6112 & GALVANIZED COATING	6 ea.
Fan Tray(unloaded)	1,5 mm	DIN EN 10130 – 99 EREGLI DC-01 6112 CRS	1 ea.
Front Door	1,5 mm	DIN EN 10130 – 99 EREGLI DC-01 6112 CRS	1 ea.
Rear Door	1,2 mm	DIN EN 10130 – 99 EREGLI DC-01 6112 CRS	1 ea.

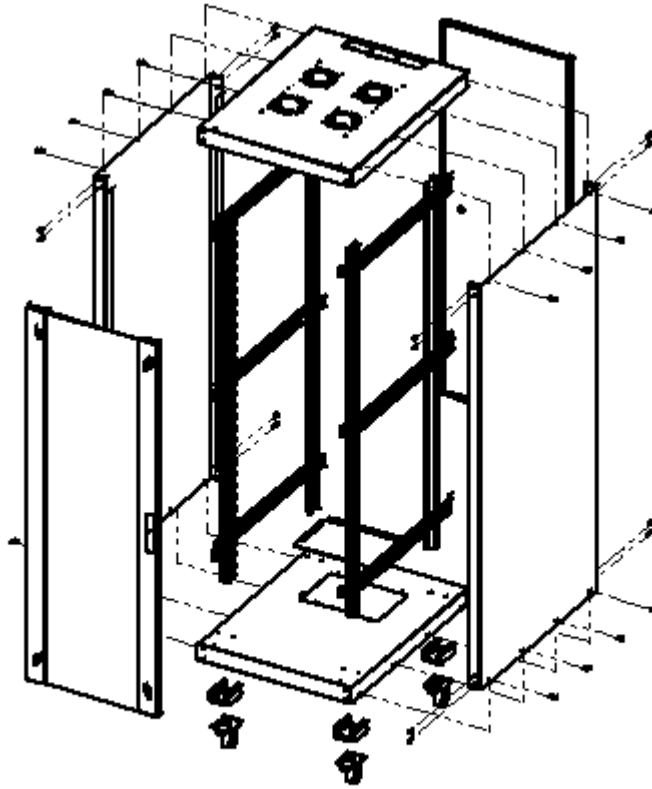

Explode View

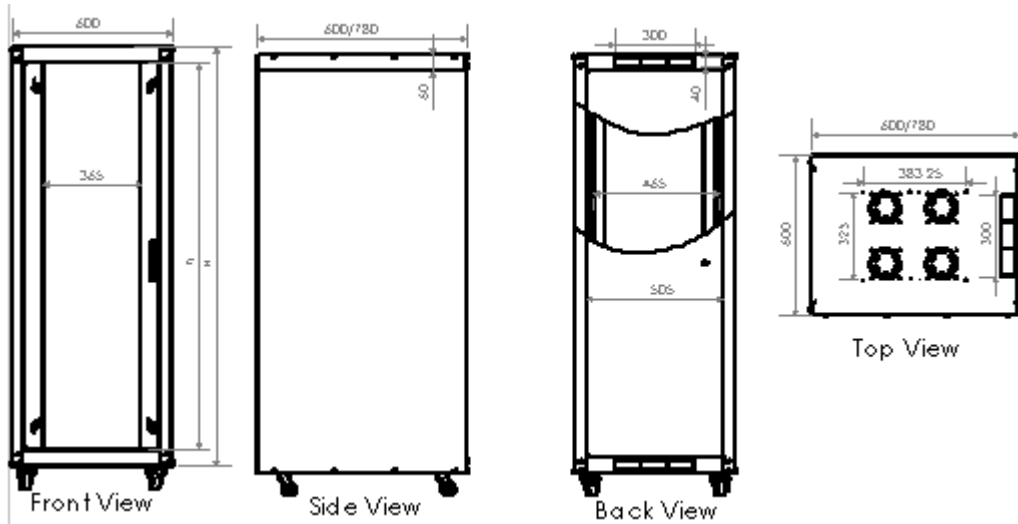

Front View

Side View

Back View

Top View

19" Digitus Ecoline Cabinets width=600 mm depth=600 mm

Order No	U = (44,45)	h= inside height(mm)	H=outside height(mm)	Total weight (kg.)	Gross weight (kg.)
176732 / DN-19 22U-6/6-EC	22	981,10	1122,00	55	63
176749 / DN-19 32U-6/6-EC	32	1425,60	1567,00	70	80
176756 / DN-19 42U-6/6-EC	42	1870,10	2012,00	87	99

19" Digitus Ecoline Cabinets width=600 mm depth=800 mm

Order No	U = (44,45)	h= inside height(mm)	H=outside height(mm)	Total weight (kg.)	Gross weight (kg.)
176732 / DN-19 22U-6/8-EC	22	981,10	1122,00	62	71
176749 / DN-19 32U-6/8-EC	32	1425,60	1567,00	81,5	92,5
176756 / DN-19 42U-6/8-EC	42	1870,10	2012,00	101	114