



DIGITUS ECOLINE 19" modular wall mounting cabinets

DIGITUS ECOLINE 19" modular wall mounting cabinets provides an economical solution for wall mount mini-cabinets. The SOHoline features a modular, sturdy and compact design, ideal installation for;

*Offices
*Schools
*Hotels

*Computer Aided Classes
*Government Offices
*Branch Offices

DIGITUS ECOLINE 19" modular wall mounting cabinets



FEATURES

*Easy to access

Front door features a full-length smoked and shatterproof glass door integral locking mechanism.

Rear door; removable with 4 screws.

*Cable access

Pre-punched two(2) brush opening, one on top, one on bottom. Removable rear cable access panel.

*Construction

Rigid frame construction in steel sheet, rapidly dismantled per 3 screw per corner.

Top base is vented, pre-punched holes are available for top mount cooling system.

19" mounting angles (front/2ea.) and allow for flexible configuration and adjustable in depth.

Extensive range of **accessories**

REDUCE ;

% 70 SHIPMENT

% 50 LABOUR COSTS

Packaging :

Unit comes in a **FLAT PACKAGE** , mininum assembly required .

Load Carrying Capacity: 30 kg

STANDARDS

*ISO 9001:2000

*19" mounting to IEC 297-1

*Overall cabinet dimensions to IEC 297-2

COMPLIANCES

UL and cUL

IP Protection: IP20

Glass : 5mm Secure and tempered

Surface Treatment : Fosfat coating

Painting : Ral7035

Locks : Emka Germany

O-type : KLT - E7308 / Password Code : 9473

Small O-type : KLT – E7158 / Password Code : 827

Well Packaged : Shrinked plastic with inner surface and outside is covered by high density cardboard .

Material Definition and Properties, Thicknesses and Shipment Configuration

Part Definition	Material thickness	Material definition & properties	Shipment Configuration
Glass Door	5 mm	Secure and Tempered	1 ea.
Side Doors	1,5 mm	DIN EN 10130 – 99 EREGLI DC-01 7122 CRS	2 ea.
19" mounting angles	1,5 mm	DIN EN 10130 – 99 EREGLI DC-01 6112 & GALVANIZED COATING	2ea. at front
Upper Case	1,2 mm	DIN EN 10130 – 99 EREGLI DC-01 6112 CRS	1 ea.
Bottom Case	1,2 mm	DIN EN 10130 – 99 EREGLI DC-01 6112 CRS	1 ea.
Rear Door	1 mm	DIN EN 10130 – 99 EREGLI DC-01 6112 CRS	1 ea.

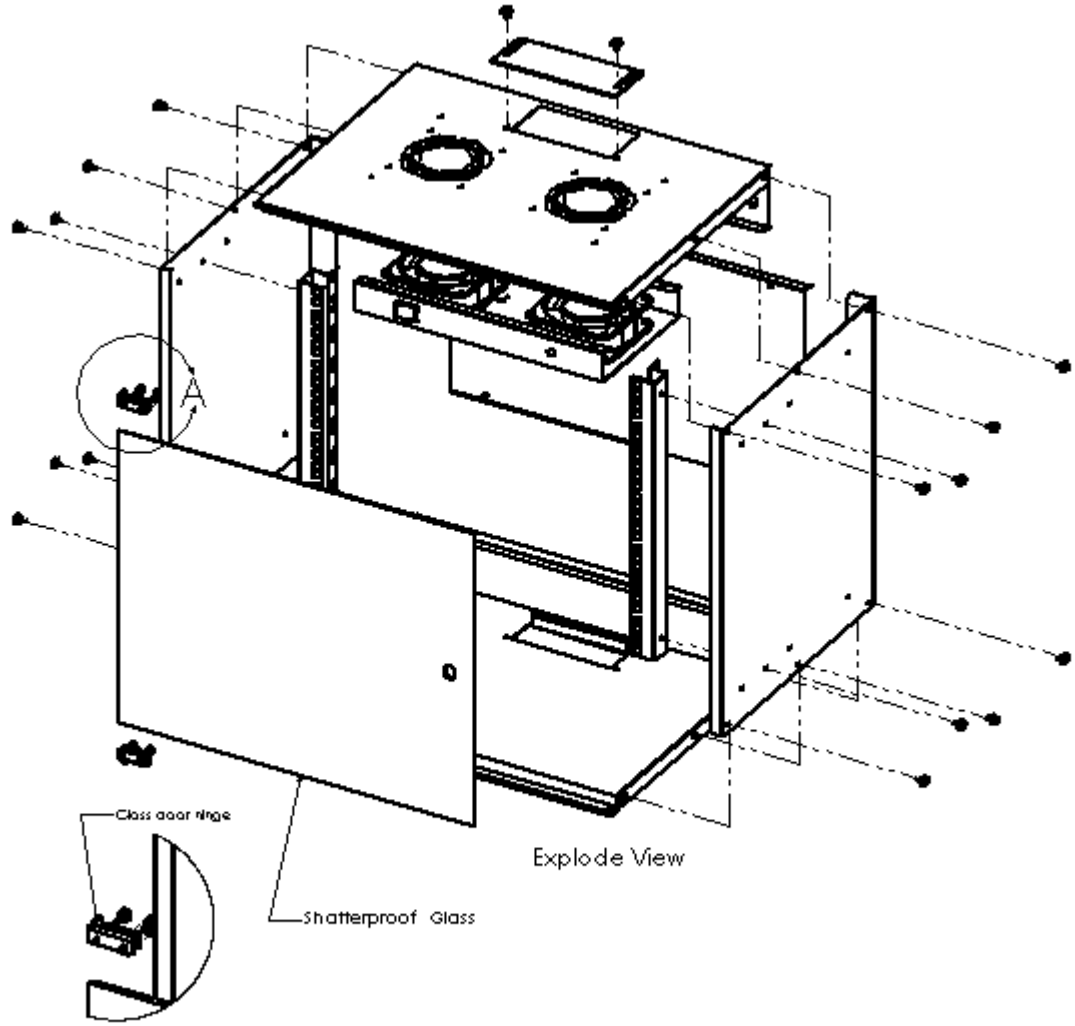

DETAIL A
 SCALE 1 : 4

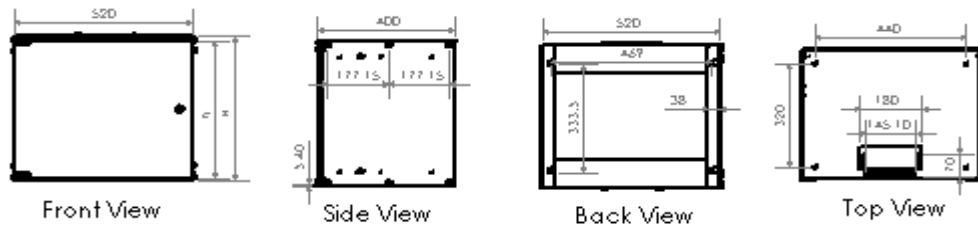

19" DIGITUS ECOLINE modular wall mounting cabinets width=520 mm depth=400 mm				
Order No	U= (44,45)	h= inside height(mm)	H=outside height(mm)	Total weight (kg.)
135241 / DN-19 07-U-S	7	314,30	359,10	16
135258 / DN-19 09-U-S	9	403,20	448,00	19
135432 / DN-19 12-U-S	12	536,55	581,35	23