

Clear Cap

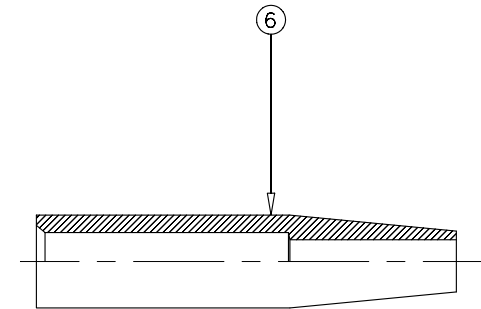
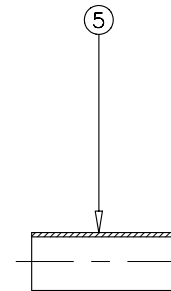
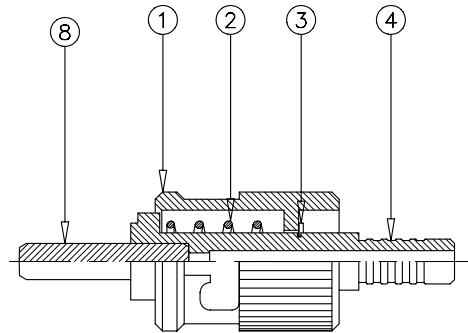

Black

DESCRIPTION

MECHANICAL :

	MATERIAL	FINISHED
1. COUPLING	ZINC ALLOY	NICKEL PLATING
2. SPRING	STAINLESS	HEAT TREATMENT
3. LOCKING RING	STEEL	NICKEL PLATING
4. FLANGE	ZINC ALLOY	NICKEL PLATING
5. BUSH	BRASS	NICKEL PLATING
6. BOOT	RUBBER	
7. CAP	PE	
8. FERRULE	ZIRCONIA($\phi 0.126^{+0.002}$)	

OPERATION :

Operation Temperature : -20°C to $+70^{\circ}\text{C}$
 Durability : 500 cycles
 Vibration : 10 to 55Hz 1.5mm double amplitude
 Temperature Cycle : -20°C to $+80^{\circ}\text{C}$
 Tensile Strength : 10 kgf

	DSGN	MAER	18.MAY.2004	ITEM NO:	ALWL-ST
	CHK				
UNIT	M/M	APPR			ST Connector for 3.0mm MM
SCALE					
DWG NO:	ASSMANN Electronic Components				
ALWL-ST					